

MI Series Microinverters

MI-400/MI-425/MI-450/MI-500 User Manual



About This Document

Corporate Contact Information

Company: ATMOCE Holding B.V.
Address: Singel 250, 1016AB Amsterdam, Netherlands
Email: info@atmoce.com
Telephone: +31 6 39877352

Disclaimer

- Product information is subject to change without prior notice. Every effort has been made in the preparation of this document to ensure accuracy of the content, but all statements, information, and recommendations in this document do not constitute a warranty of any kind, express or implied.
- For optimum reliability and to meet warranty requirements, this product must be installed in accordance with the instructions in this manual.
- For more information about the warranty, visit <https://>

Applicable Scope

- This manual is intended for professional installation and maintenance personnel only.
- This manual mainly introduces the assembly, installation, configuration, maintenance, and troubleshooting methods of the following types of microinverters:
MI-400 / MI-425 / MI-450 / MI-500

Revision History

	Date	Version	Description
1	2024-09-10	Preliminary	For testing purposes only

Contents

About This Document	I
Corporate Contact Information	I
Notice	I
Applicable Scope	I
Revision History	II
Contents	III
Safety Information	01
1.1 Statement	01
1.2 Safety Labels	01
1.3 Personal safety instructions	02
1.4 Microinverter Safety Instructions	03
1.5 Cable Safety Instructions	04
1.6 Environment Instructions	05
Product Information	06
2.1 Atmoce System	06
2.2 MI Series Microinverters	08
Storage Requirements	13
Installation	14
4.1 Preparations	14
4.2 Mount the Microinverters	19
4.3 Connect the AC Output of the Microinverters	20
4.4 Cover the Unused End of the Cable	20
4.5 Connect to the AC Junction Box	21
4.6 Arrange the Cables	22
4.7 Create the Installation Map	23
4.8 Connect the PV Modules	24

4.9 Activate the System	25
Troubleshooting	26
5.1 LED Indicator	26
5.2 Troubleshooting	27
5.3 View the Alarm Codes	30
5.4 Alarm Code List	31
Maintenance	33
6.1 Remove the Microinverter	33
6.2 Replace the Microinverter	35
Technical Data	36
7.1 MI Series Microinverters Data Sheet	36
Appendix 1: Installation Map	38
Appendix 2: Wiring Diagram in Single-phase System	39
Appendix 3: Wiring Diagram in Three-phase System	40
Appendix 4: Terms and Abbreviations	41

Safety Information

1.1 Statement

- Before installing or using an Atmoce microinverter, please carefully read the user manual, all instructions and safety labels on the device, and any safety manuals available. Not following these safety instructions may result in personal injury, damage to the device, or invalidation of the warranty.
- DANGER, WARNING, CAUTION, and NOTE in this manual imply that they must be observed. You must also comply with relevant international, national or regional standards and industry practices. Atmoce assumes no responsibility for any violation of safe operation requirements or of safety standards for the design, manufacture and use of the device.
- This device should be used in an environment that meets the design specifications; otherwise, the device failure, abnormal device functions, or component damage that may be caused by the device will not be covered by the warranty.
- All operations such as transport, storage, installation, operation, use, maintenance, etc. should comply with applicable laws, regulations, standards and specifications.

1.2 Safety Labels

To reduce the risk of electric shock and ensure the safe installation and operation of the device, the following safety labels are used throughout this manual to indicate hazardous conditions and important safety instructions.



Danger

Indicates a high-level hazard which, if not avoided, will result in death or serious injury.



Warning

Indicates a medium-level hazard which, if not avoided, could result in death or serious injury.



Caution

Indicates a low-level hazard which, if not avoided, could result in minor or moderate injury.



Note

Indicates a safety hazard which, if not avoided, may result in device damage, data loss, performance degradation, and other consequences.

1.3 Personal safety instructions



Danger

- Working live is strictly prohibited during the installation process. Do not install or remove cables while they are live. Transient contact between the core of the cable and a conductor will generate electric arcs or sparks, which may cause a fire or personal injury.
- When the device is energized, unregulated and incorrect operation may lead to a fire, electric shock, or explosion, resulting in personal injury, death, or property damage.
- Do not work alone. When you are working on or near the electrical device, someone should be within earshot or close enough to help you. Remove rings, bracelets, necklaces, watches, etc. when working with PV modules, microinverters, or other electrical devices.



Warning

- Specialized protective equipment must be used during the operation, such as safety clothing, insulating shoes, goggles, helmets, and insulating gloves.
- Do not ignore warnings, cautions, and precautions in manuals and on device.
- During device operation, if a malfunction that could result in personal injury or device damage is detected, immediately terminate the operation, report it to the person in charge, and take effective protective measures.
- Do not apply power to the device before installation is completed or without confirmation from a qualified person.
- Atmoce microinverters have heat dissipation function. Under normal operating conditions, the microinverter temperature can be 20 °C higher than the ambient temperature. Under extreme conditions, the microinverter temperature can reach 90 °C. To reduce the risk of burn, be careful when working with the microinverter.



Note

- Do not permit installation by untrained personnel. Atmoce shall not be liable for any loss or damage caused by improper use, installation, or misuse of the device.
- Personnel responsible for installing and maintaining the device must be adequately trained and aware of the various safety precautions and relevant standards in their country/region.
- Personnel in special scenarios such as work live, work at heights, and operation of special devices must have special operating qualifications required by the local country/region.

1.4 Microinverter Safety Instructions



Danger

- Do not attempt to repair the microinverter without authorization, as they contain no user-serviceable parts. Unauthorized disassembly, repair, or destruction of the microinverter and its internal parts will invalidate the warranty and may result in personal injury. If the microinverter malfunctions, please contact Atmoce technical support.
- Do not use the microinverter in any way, other than as specified by Atmoce, as unauthorized use may result in personal injury or device damage.
- Do not use accessories that have not been approved by Atmoce, as this may result in device damage or personal injury.
- Improper installation of the microinverter may result in an electric shock, fire, or explosion. To reduce these risks, ensure that the circuit breaker is in the OFF position and that the output is disconnected from the microinverter before installation, maintenance, or cleaning.
- Do not operate the microinverter if it has visible damage.



Warning

- Check that the cables and connectors are in good condition, and do not operate the microinverter with damaged or unqualified cables or connectors.
- The maximum open-circuit voltage of the PV modules must not exceed the maximum DC input voltage of the microinverter. Incompatible PV modules may cause damage to the device and void the warranty.
- The number of microinverters connected to each PV branch must not exceed the maximum number specified in this manual.
- Install the microinverter under the PV module to avoid direct exposure to rain, UV radiation, and other harmful weather events.
- Moisture trapped in the cables will damage the microinverter. Therefore, do not connect the microinverter directly to cables exposed to damp conditions; otherwise, the warranty will be invalidated.
- The microinverter cannot support devices such as intelligent PV modules, fuel cells, wind or water turbines, and DC generators. These devices do not behave like standard PV modules and may damage the microinverter.

**Note**

- When installing the microinverter, comply with installation regulations and/or local electrical codes.
- The microinverter is suitable for operation in an ambient temperature of -40–65 °C.
- When connecting the microinverter to the PV module, ensure that the DC cable of the PV module is labeled "PV Wire" or "PV Cable" and that the connector is an MC4 connector.
- Provide support for AC cables at least every one meter.
- The microinverter may need to be set up in the grid profile according to local requirements. Adjustments should only be made by a qualified and authorized installer with the approval of the local electricity authority.
- If there is no grid profile that meets the requirements of the local electricity authority, please contact Atmoce technical support and request a new customized grid profile.
- Do not connect the microinverter to the grid or energize the AC circuit(s) until all installation procedures have been completed and the grid operator has given approval.
- It is strictly prohibited to artificially alter, damage, or cover the markings and nameplates on the device, and it is recommended to promptly replace markings that have become unclear due to prolonged use.
- It is prohibited to clean the electrical parts inside and outside the device with water, alcohol, oil, or other solvents.

1.5 Cable Safety Instructions

**Danger**

- Do not attempt to install cables unless the circuit is disconnected.
- Take care not to damage the copper conductor of the cable when stripping the cable sheath. If the exposed wires are damaged, the system may not function properly.

**Warning**

- Ensure that AC and DC wiring is correct and that none of the AC or DC cables are pinched, shorted, or damaged. Ensure that all AC junction boxes are properly closed.
- Do not leave the connectors on the cable uncovered for long periods of time. Unused AC connectors must be covered with caps.

- Do not expose terminals or cable connectors to continuous tension, and avoid pulling or bending the cable at the connection.
- Avoid routing cables with overly tight cable clamps.
- Cable entry holes should be free of sharp edges to avoid damage to the cables by sharp edges and burrs.
- Ensure that the cable connector is free of dirt or debris.

1.6 Environment Instructions



Danger

- Do not place or operate the device in a flammable or explosive atmosphere.
- Do not install or use the device in a potentially explosive environment.
- Do not place the device near sources of heat or ignition, such as fireworks, candles, and heaters; otherwise, device damage or fires may occur.
- Do not expose the device to direct sunlight.



Warning

- Do not attempt to install the device in adverse weather conditions.
- Do not expose terminals or connectors to pressurized liquids, such as water jets.
- Do not continuously immerse terminals or connectors.
- Do not install the device in an environment with volatile gases, corrosive gases, or organic solvents.
- Do not install the device in an area with strong vibration, apparent noise sources, and a lot of electromagnetic interference.
- After device installation, clear away empty packing materials, such as cardboard boxes, foams, plastics, and cable ties.

Product Information

2.1 Atmoce System

2.1.1 Overview

The system includes the following:

- **Microinverter (MI-400/MI-425/MI-450/MI-500):** Atmoce microinverters are compact and efficient devices for home distribution systems. They are grid-connected to convert the DC output of a PV module into an AC grid.
- **M-Combiner (MC100/MC100L/MC100-T):** It is an energy management equipment that ensures the proper connection of microinverters, batteries, and loads, and enables grid connection to the distribution panel.
- **Atmoce-Cloud:** It is a web-based energy management portal, where you can view operation details, manage energy systems, and resolve system issues remotely. For more information, visit <https://www.atmocecloud.com>.
- **Atmozen app:** It is a mobile app running on either iOS or Android to provide the following features: remote module management, home energy management, and 5-second data refresh.
- **Battery**
- **AC EV charger, heat pump or other residential loads**

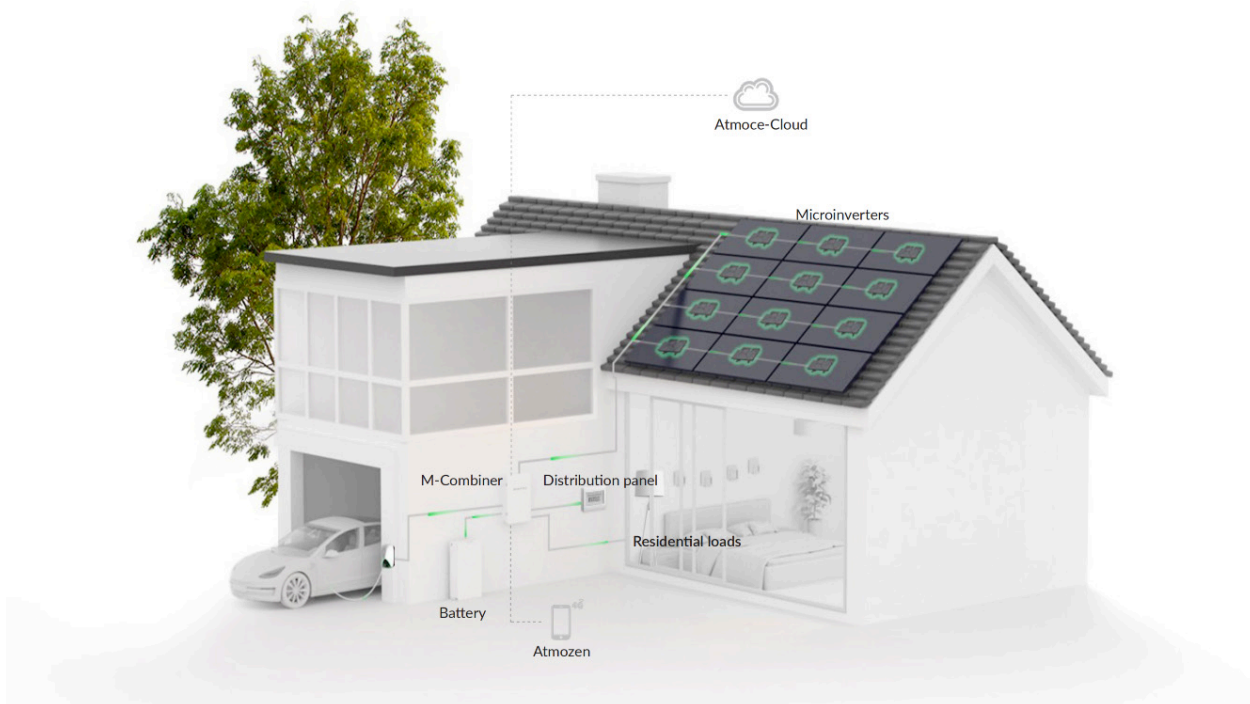

2.1.2 Functional characteristics

- **Safety**

The Atmoce system eliminates hazards associated with high-voltage DC, protecting homeowners and installers from potential electrical environment dangers. In addition, the system is resistant to extreme weather conditions and can operate reliably even in harsh environments.

- **High Reliability**

The microinverters operate independently to ensure a low failure rate, minimizing the impact of single point of failure on the entire system and ensuring continuous, uninterrupted power generation.

- **Flexibility and Intelligence**

The system is AC-coupled to allow for flexible system expansion as needed, specifically, PV module adding. In addition, the system incorporates digital real-time monitoring to accurately measure and control the power generation status.

- **Excellent Compatibility**

The system leverages the grid forming design to ensure seamless integration with the grid. It supports multiple types of energy resources, such as solar, wind, and the grid. This versatility allows the system to adapt to changing energy demands and sources, promising a reliable and sustainable energy solution.

2.2 MI Series Microinverters

2.2.1 Overview

Atmoce microinverters are compact and efficient devices for home distribution systems. They are grid-connected to convert the DC output of a PV module into an AC grid. With the peak efficiency of up to 97.3% and the maximum power point tracking (MPPT) efficiency of up to 99.9%, Atmoce microinverters ensure maximum utilization of solar energy.

Atmoce microinverters are compatible with various PV modules, implementing flexible application in different scenarios, such as roof and balcony. The Atmoce microinverter system helps homeowners achieve energy independence.

2.2.2 Functional characteristics

- **Safety and Reliability**

Atmoce microinverters are IP67-rated and rugged to ensure optimal performance in harsh environmental conditions. They have undergone rigorous reliability testing, with over 1,000,000 hours of test time, to guarantee reliability and durability for 25 years.

- **High Energy Yield**

With a peak efficiency of 97.4%, Atmoce microinverters maximize the conversion of available sunlight into usable power. Furthermore, 99.9% MPPT efficiency ensures that the system operates at the optimal point to extract maximum power from PV modules at all times.

- **Easy Installation**

An Atmoce microinverter weighs just 1.3 kg and utilizes the power line communication (PLC) technology to eliminate the need for additional cables. The MW plug-and-play cable simplifies installation. This flexibility allows PV modules to be configured based on your specific requirements.

- **Flexibility and Intelligence**

Atmoce microinverters meet the needs of every scenario and support all common PV modules of up to 700 W, making them ideal for installation on a roof, balcony, or any other location. Atmozen, an all-in-one app, monitors the performance of each module in real time, allowing you to optimize your system for maximum efficiency.

2.2.3 Application Scenarios

Atmoce microinverter should connect to a single-phase or a three-phase grid. Measure AC line voltages at the point of connection to confirm that they are within the ranges.

Phase setup	Voltage range	
Single-phase	L to N	184 to 276 Vac
Three-phase	L1, L2, L3 to N	184 to 276 Vac

• Single-phase

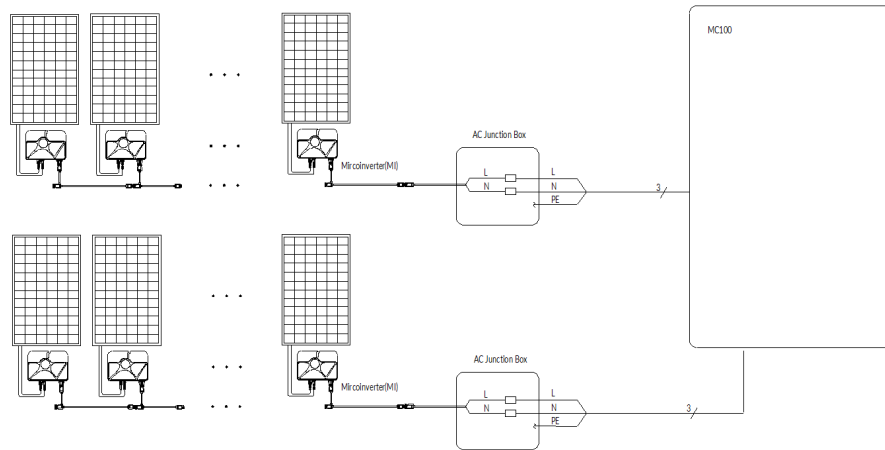

• Three-phase

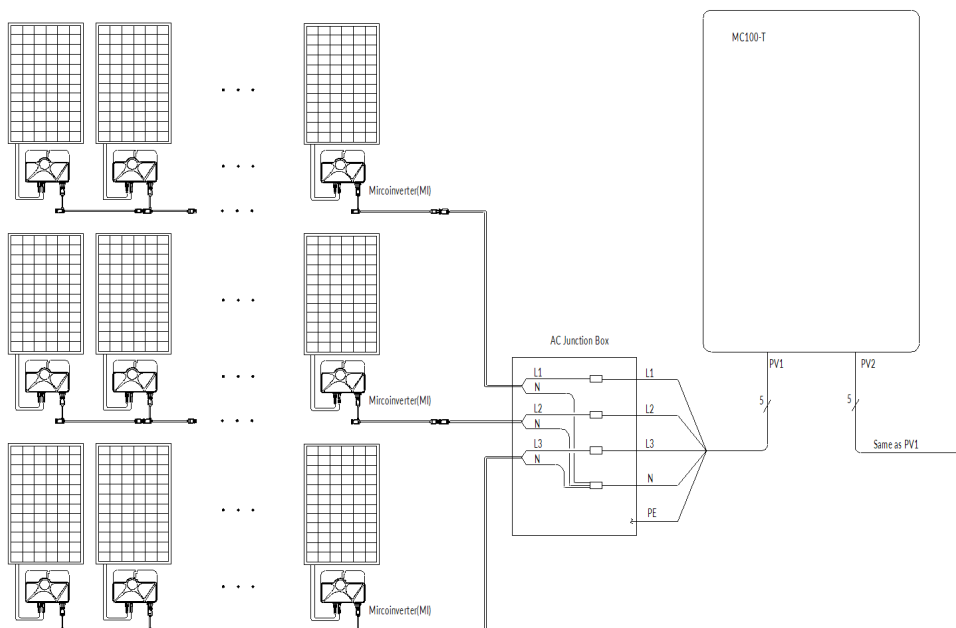

2.2.4 Models

This manual mainly covers the following product models:

Model	Nominal Output Power
MI-400	400 W
MI-425	425 W
MI-450	450 W
MI-500	500 W

2.2.5 Microinverter Structure

Dimensions

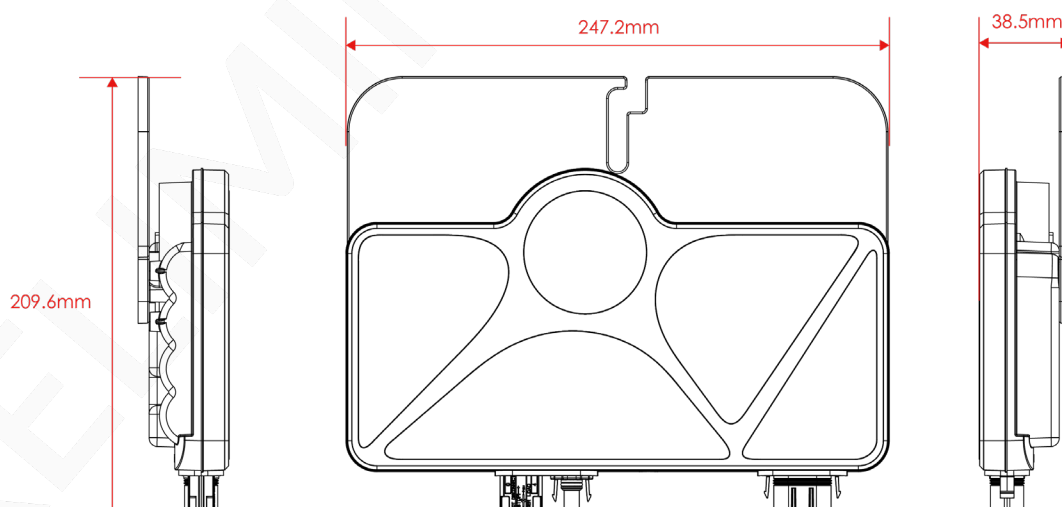

Interfaces

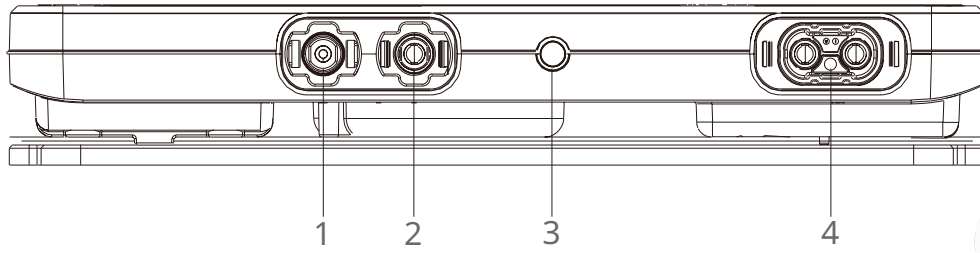

1. DC Connector + 2. DC Connector - 3. LED 4. AC Connector





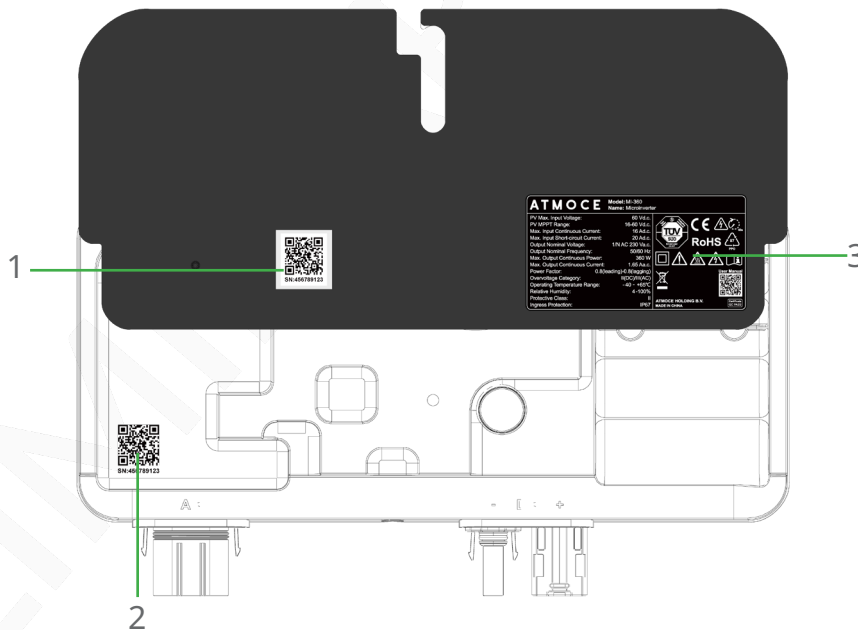



Connector	Pair	Type	Compatibility
DC connector	1	MT-02502-D	The DC connector is compatible with MC4
AC connector	1	MT-02502-A	The AC connector must be used with MW-Cables

2.2.6 Microinverter Labels



- 1. Microinverter Serial Number QR Code Sticker
- 2. Microinverter Serial Number QR Code
- 3. Nameplate Label

Nameplate Label Instruction

Lable	Description
	Risk of burn. Do not touch the enclosure of the microinverter, as its temperature will become high during operation.
	Risk of electric shock. Switch off the power to the circuit breaker(s) you're working with.
	Made from PPO material, do not heat or expose to direct sunlight.
	The product has passed CE related certification.
	Waste electrical and electronic equipment (WEEE), which cannot be treated as household waste and should be returned to Atmoce or disposed of in accordance with local regulations.
RoHS	Restriction of Hazardous Substances (ROHS)-compliant.
	Class II or double insulated electrical device, requiring no earth connection.
	Please read the user manual before using the equipment.
	Delayed discharge. Wait 60 seconds for the unit to fully discharge after it is powered off.

Storage Requirements

This section describes requirements for storing the device before it is installed and used. Noncompliance will void the warranty.



- Do not remove the outer packaging of the device.
- The storage temperature range should be -40–85 °C.
- The relative humidity range should be 40%–60% RH.
- Store the device in a clean and dry place, away from dust and moisture.
- Stack up to eight layers. Be careful and avoid personal injury or device damage caused by a tipping.
- It is recommended to perform an inspection once every three months.
- If the device has been stored for two years or longer, it must be inspected and tested by qualified personnel before use.

Installation

4.1 Preparations

4.1.1 Check the Items in the Package

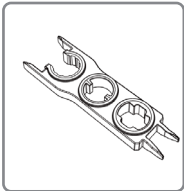
Ensure that the following items are included in the package before installation.

Item	Model	Description	Usage
	MA-001	Disconnect tool	To disconnect connectors.
	MA-003	Installation map	To record the SN and installation position of microinverters.
	/	Quick installation guide	To guide on-site installation.

4.1.2 Check the Electrical Compatibility of PV Modules

Model	Connector	PV Module (Cell Count)
MI-400/MI-425/ MI-450/MI-500	MT-02502-D	Pair with 54-cell/108 half-cell, 60-cell/120 half-cell, 66-cell/132 half-cell, or 72-cell/144 half-cell

NOTE:

- The maximum open-circuit voltage of PV modules cannot exceed the maximum DC input voltage of Atmoce microinverters. Incompatible PV modules may result in the device damage and void the warranty.

4.1.3 Plan the Number of Microinverters on each PV AC Branch

The number of microinverters on each PV AC branch shall not exceed the following limits respectively:



Model	Max microinverters/20A branch ^a	Max microinverters/25A branch ^b
MI-400	8	11
MI-425	7	10
MI-450	7	10
MI-500	6	9

a. Output overcurrent protection is provided by a type C circuit breaker inside the M-Combiner, rated at 20A for MI-400/MI-425/MI-450/MI-500.

b. You can replace the PV breaker with one rated at 25A and select the cables that meet the local electrical code requirements.

4.1.4 Select M-Cable Models

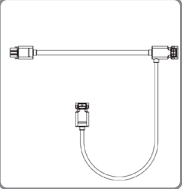
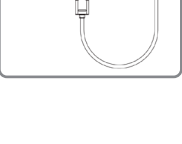
When planning the system, it is necessary to select appropriate cables. Atmoce provides the following cable models:

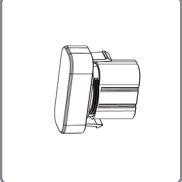
	Model	Description	Usage
	MW-025013-A	Three-terminal AC cable Length: 1.3 m Copper conductor size: 2.5 mm ²	To mount PV modules in portrait.
	MW-025023-A	Three-terminal AC cable Length: 2.3 m Copper conductor size: 2.5 mm ²	To mount PV modules in landscape.
	MW-025020-B0	Two-terminal AC cable Length: 2 m Copper conductor size: 2.5 mm ²	AC extension cable
	MA-002	AC cable sealing cap	To cover unused connectors of AC cables

NOTE:

- Atmoce microinverters must be connected with the above cables. To purchase them, please contact Atmoce sales personnel.

4.1.5 Prepare the Tools and Materials

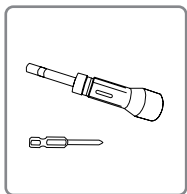

Screwdriver
(M8)

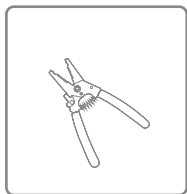

Wire stripper

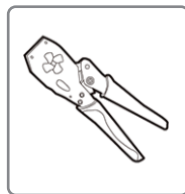

Power line crimper



Communication
line crimper

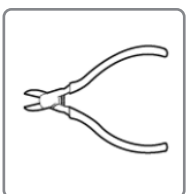

Diagonal cutter

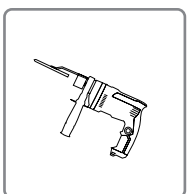

Drill

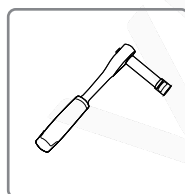

Torque wrench

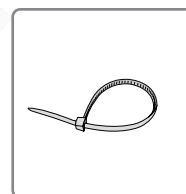

Tie wrap

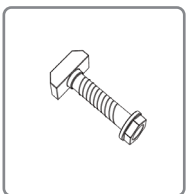

T-shaped screws
and nuts
(M8)

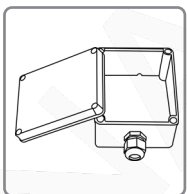

AC Junction box

4.1.6 Prepare the Safety Equipment



Safety helmet

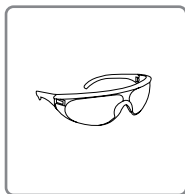

Protective goggles

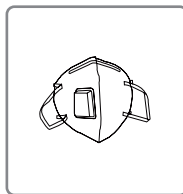

Mask



Safety clothing

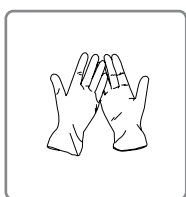

Safety gloves

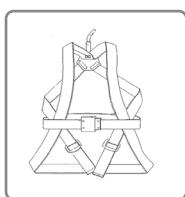

Safety belt



Safety shoes

4.2 Mount the Microinverters

- Plan the installation positions of the microinverters after installing the PV rack. It is recommended to install microinverters at the approximate center position of the PV modules.
- Use T-shaped screws to mount the mounting plate of the microinverter onto the PV rack, as shown in the figures.

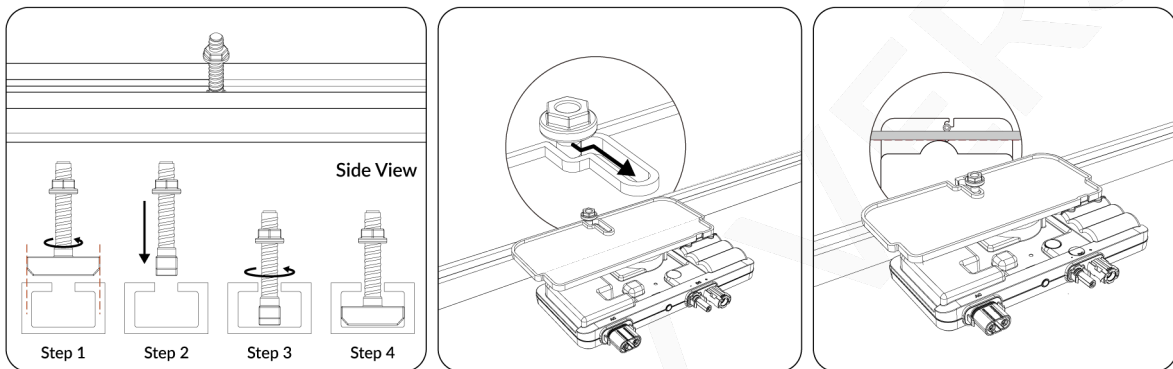

- Maintain the torque within 9-14 N·m (M8 screw).

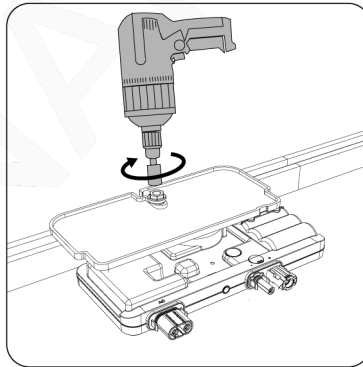

NOTE:

- Microinverters should not be directly exposed to rain, sunlight, UV radiation, and other harmful weather conditions.

4.3 Connect the AC Output of the Microinverters

- Locate the M-Cables along the PV rack.
- Connect Terminal TC to the AC connector of the microinverter, and connect Terminal TB to Terminal TA of the next cable. When any two connectors are properly connected, a "click" sound can be heard.
- If two microinverters are far away from each other, consider using MW-025020-B0 for cable extension.

NOTE:

- To disconnect the AC connectors, a disconnect tool must be used to avoid damaging the device and voiding the warranty. For detailed instructions, refer to Section 6.1 Remove the Microinverter.

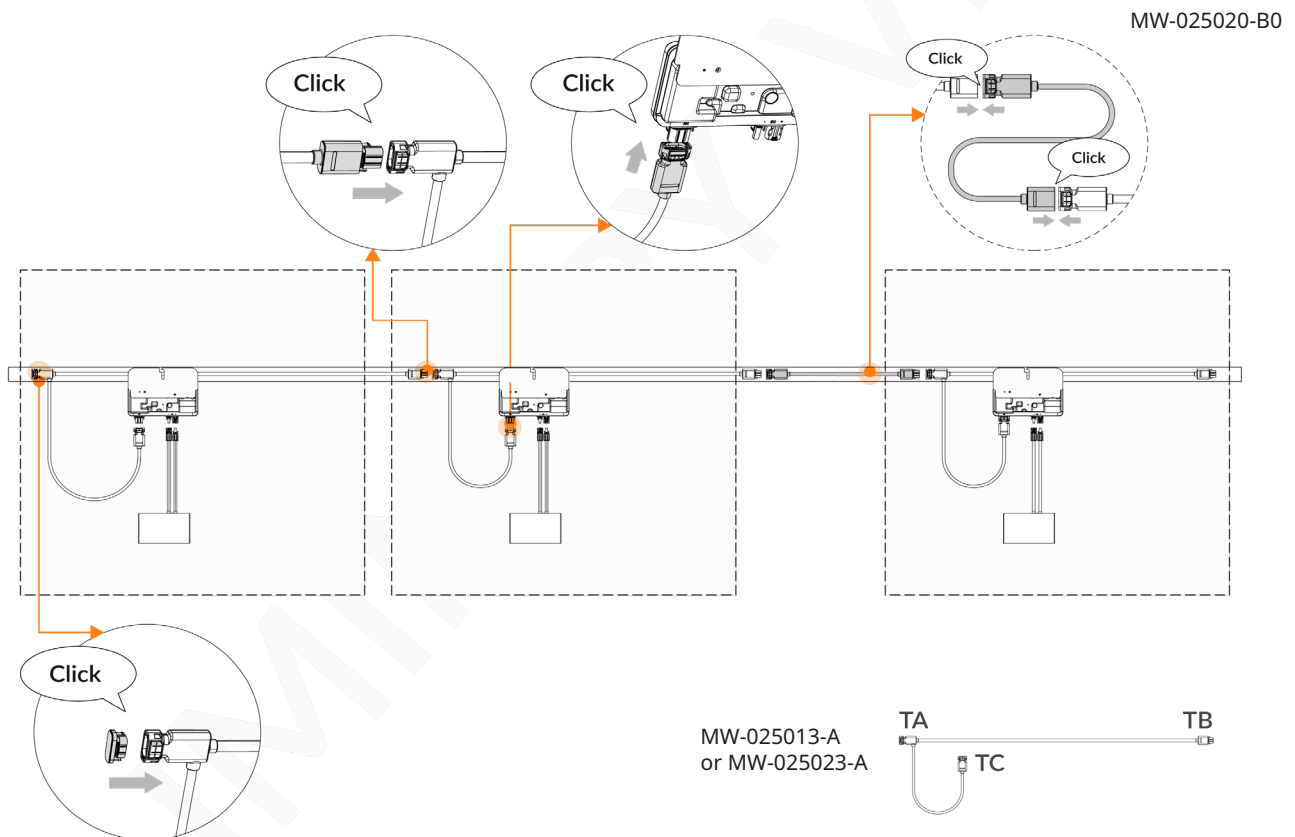

4.4 Cover the Unused End of the Cable

- Use the sealing cap to cover any unused AC connectors at the end of the AC cable. When the sealing cap is placed properly, a "click" sound can be heard.

NOTE:

- All unused AC connectors need to be covered with sealing caps to avoid risks such as short circuits when the AC branch is energized.

4.5 Connect to the AC Junction Box

- Use the wire stripper to cut off the AC connector at the end of the PV AC branch.
- Remove approximately 25 mm of the cable sheath, and peel off approximately 12 mm of the insulation layer from the L and N wires.
- Connect the AC cable into the AC junction box and crimp the cables as shown below.
- Mount the junction box in a suitable position, such as on a roof or wall.
- Close the lid of the AC junction box.

NOTE:

- It is recommended to use a waterproof AC junction box.
- When crimping cables, do not expose the copper conductor to avoid the risk of short circuits.

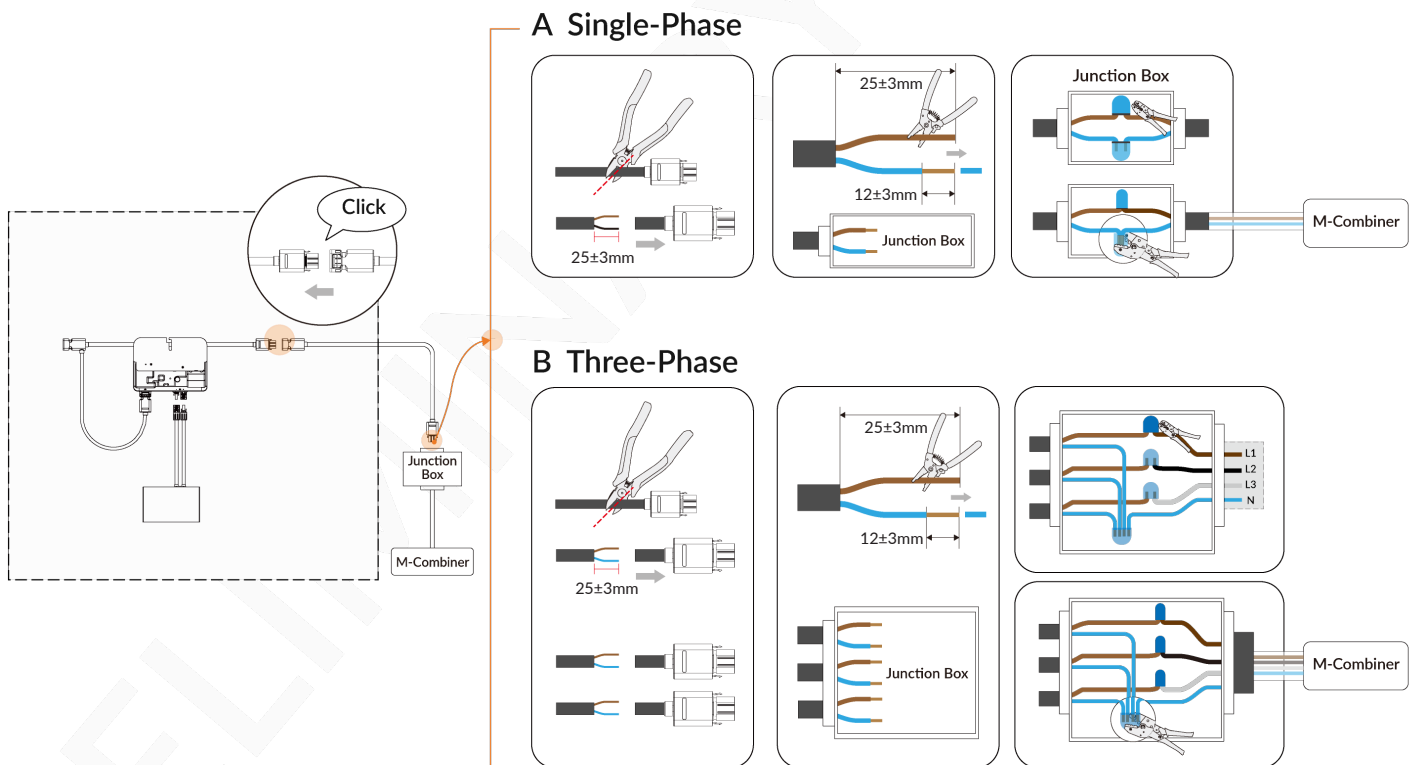

4.6 Arrange the Cables

- Use cable clips or tie wraps to attach the cables to the PV rack.
- The cables should be supported at least every 1 meter.
- Bundle and secure excess cables to prevent cables or connectors from touching the roof.

NOTE:

- Tie wrap should not be directly exposed to the sunlight.

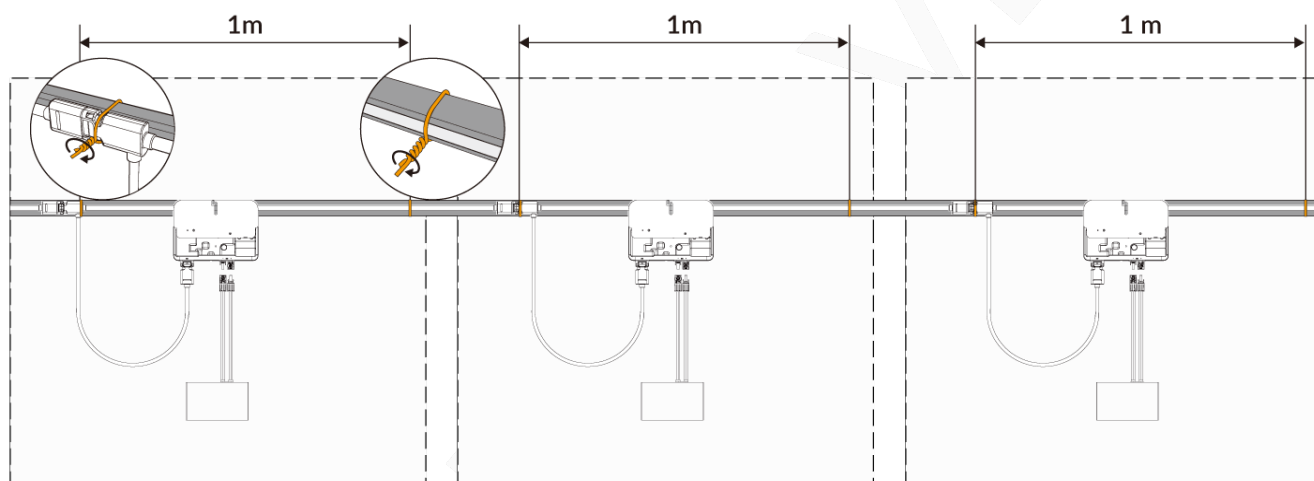

4.7 Create the Installation Map

- Take out the paper installation map from the package and record the SNs and positions of the microinverters in the PV array.
- Peel off the detachable SN label (QR code) from the mounting tab of each microinverter and affix it to the corresponding position in the installation map.

NOTE:

- Keep the installation map properly. Input the layout details to Atmozen to record the SNs and configure the system accordingly.

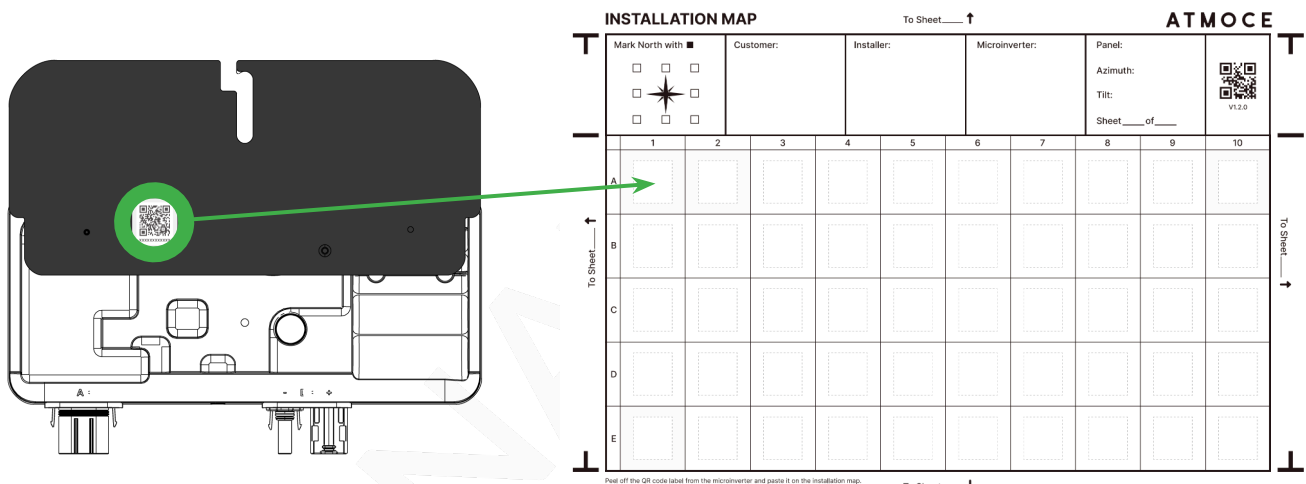

4.8 Connect the PV Modules

- Connect the DC connectors of each PV module to the DC input connectors of the microinverters. When any two connectors are properly connected, a “click” sound can be heard.
- Check the LED indicator of the microinverter. If the LED indicator is on, the microinverter is properly connected to the PV module.
- Mount the PV modules to the PV rack.

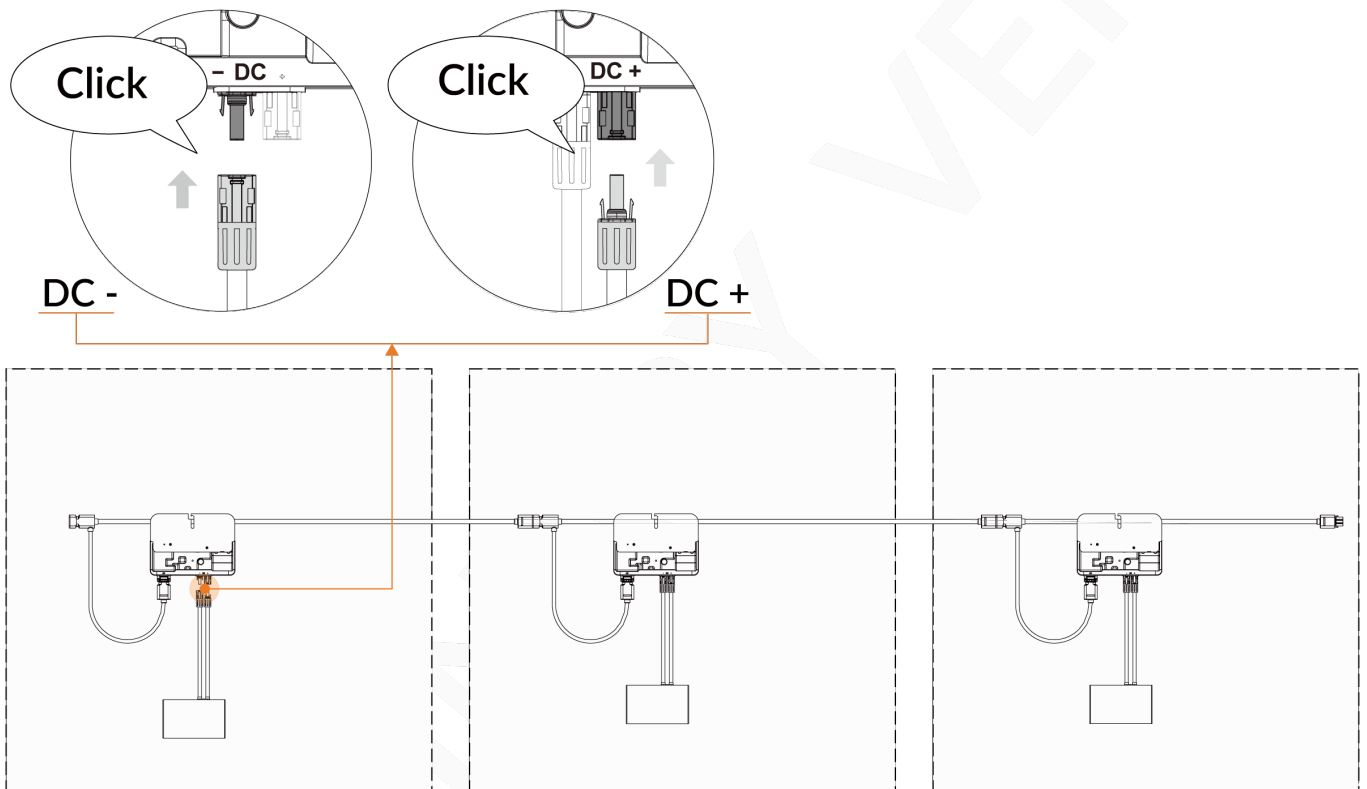

4.9 Activate the System

a. For more information about how to activate the microinverters, gateway, combiner, and app, refer to M-Combiner Quick Installation Guide/User Manual. The manual will guide you through the following operations:

- How to install a combiner.
- How to connect devices to the Atmoce-Cloud.
- How to configure devices and grid profiles.
- How to create on-site installation map on Atmozen.

NOTE:





- Microinverters will output AC power only after M-Combiner is installed and the system is activated.
- After the activation, the system may download a version upgrade, which takes 5–10 minutes before power generation.
- After M-Combiner is connected to Atmoce-Cloud, the network service is activated. Atmoce-Cloud will support updates and upgrades for all connected devices.



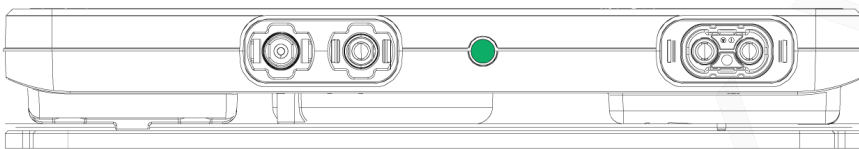



Troubleshooting

5.1 LED Indicator

- A microinverter has one LED indicator as shown below. The LED indicator shows the operation status, which helps troubleshoot on-site installation and configuration issues.
- The following table describes different statuses of the LED indicator.



-  Solid ON
-  Quick flash:
0.2s ON, 0.2s OFF
-  Slow flash:
1s ON, 1s OFF
-  Dim

	LED indicator		Description
Green	Slow flash		Normal operation.
	Quick flash		The microinverter is starting up.
Orange	Quick flash		The microinverter is waiting for upgrade or upgrading.
Red	Slow flash		The AC grid is abnormal.
	Quick flash		The working conditions are abnormal.
	Solid		The microinverter has an internal fault.

5.2 Troubleshooting

This section describes how to troubleshoot on-site issues based on the LED indicator status.

If you have any questions about the fault diagnosis, please contact Atmoce's official technical support (<https://>).

5.2.1 LED Flashing Slowly in Red

- Issue 1: The AC grid is abnormal.
 - a. Check the alarm code on Atmozen and obtain the solution. For more information about alarm codes, refer to Section 5.4 Alarm Codes.
 - b. As you troubleshoot, refer to the following process:
 1. Check that the breaker in the distribution panel is operating properly and in the ON position.
 2. Check the connection to the grid and ensure that the voltage is within the acceptable range.
 3. Check that the PV breaker and grid breaker in M-Combiner are operating properly and in the ON position.
 4. Check that the LED indicator of M-Relay is steady green.
 5. Use the disconnect tool to disconnect the AC connector of the problematic microinverter.
 6. Check that the microinverter is connected to the grid by measuring the L-to-N voltage (valid range: 184–276 V) on the AC cable connector with a multimeter.
 7. Measure the grid frequency with a multimeter or contact the grid network operator to check that the grid frequency is within the acceptable range.
 8. Replug and check that the AC branch connectors are tight.

5.2.2 LED Flashing Quickly in Red

- Issue 1: High DC input voltage of the PV module.
 - a. Check the alarm code on Atmozen and obtain the solution. For more information about alarm codes, refer to Section 5.4 Alarm Codes.
 - b. As you troubleshoot, refer to the following process:
 1. Switch off the PV breaker in the M-Combiner or shut down the microinverter using the Atmozen app.
 2. Use the disconnect tool to disconnect the connector of the faulty microinverter and wait 3–5 minutes to check whether the LED indicator becomes dimmed.
 3. Check that the DC voltage of the PV module is within the acceptable range as specified in the data sheet.
 4. Reconnect the PV module. A “click” sound indicates proper connection. Check that the LED indicator is flashing slowly in green.
 5. Connect the problematic microinverter to a known compatible PV module. Wait a few minutes and check the Atmozen app. If the fault persists, the microinverter is faulty. In this case, contact Atmoce technical support. If the fault is rectified, the original PV module is incompatible.
- Issue 2: The insulation resistance (IR) of PV modules and microinverters is insufficient. An IR sensor in the microinverter measures the resistance between the positive and negative PV inputs to the ground. If either resistance drops below the threshold, the microinverter stops generating power and reports this issue. This may indicate defective module insulation, defective wiring or connectors, or moisture ingress. In this case, observe the following procedure:
 - a. Check the alarm code on Atmozen and obtain the solution. For more information about alarm codes, refer to Section 5.4 Alarm Codes.
 - b. Check the insulation between the solar panel and the ground. If there is a short circuit or poor insulation, rectify it.
 - c. If the fault persists, contact Atmoce technical support.

5.2.3 LED Solid Red

- Issue 1: The microinverter may have an internal fault.
 - a. Disconnect the DC input from the PV module and wait 3–5 minutes before re-powering.
 - b. If the fault persists, contact Atmoce technical support.

5.2.4 LED Dimmed

- Issue 1: The sunlight is not enough.
 - a. Check that the sunlight is enough.
- Issue 2: DC input is lower than the lower limit or the microinverter is damaged.
 - a. As you troubleshoot, refer to the following process:
 1. Reconnect the PV module. A “click” sound indicates proper connection. Check that the LED indicator is flashing slowly in green.
 2. Connect the problematic microinverter to a known compatible PV module. Wait a few minutes and check the Atmozen app. If the fault persists, the microinverter is faulty. In this case, contact Atmoce technical support. If the fault is rectified, the original PV module is incompatible.

5.3 View the Alarm Codes

View the Alarm code on Atmozen as follows:

- Click the site status.
- Select the faulty device to view the details.

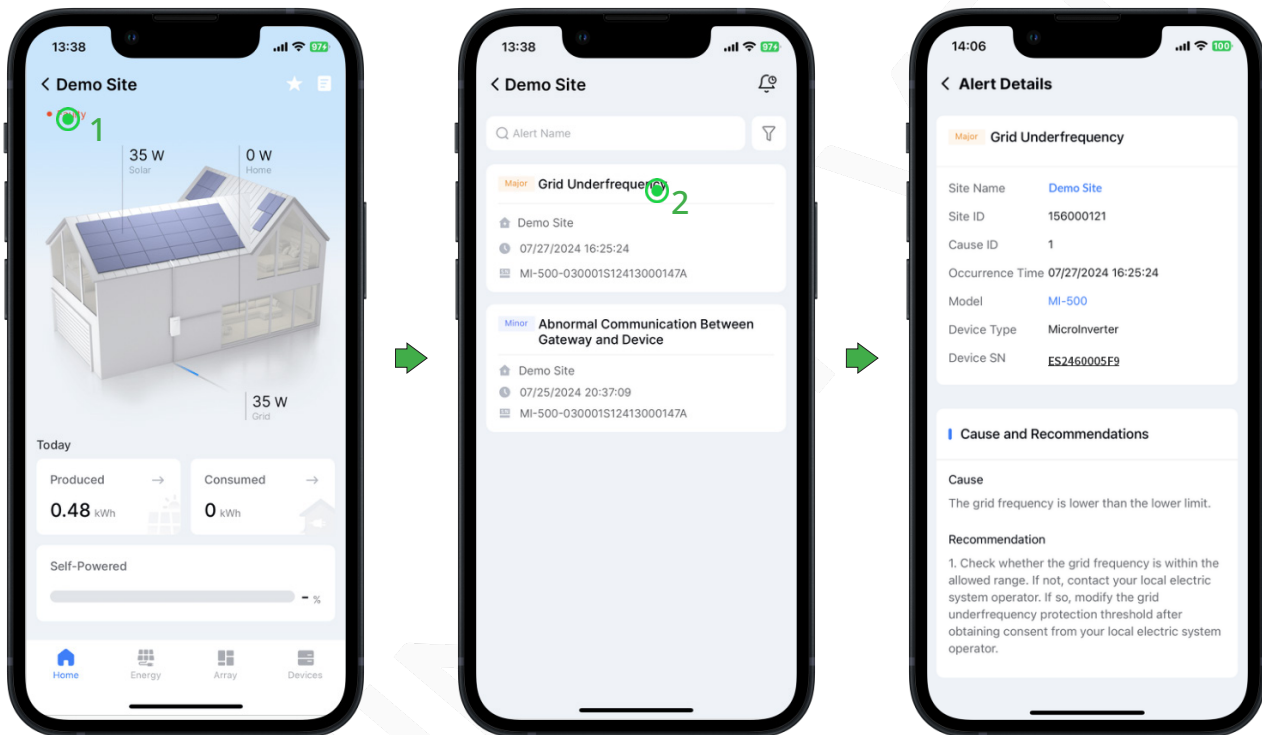

NOTE:

- Alarm codes can be viewed on Atmozen only after the system is activated.
- Alarm codes are available only if the site status is **Faulty** or **Offline**.

5.4 Alarm Code List

The following table describes alarm codes about microinverter issues.

Code	Issue	Cause	Solution
1	High Direct Current Input Voltage	The open-circuit voltage of the PV module is set to a value higher than the maximum operating voltage of the device.	<ul style="list-style-type: none"> Check whether the open-circuit voltage of the PV module is higher than the maximum input voltage of the device specified in the user manual. If so, configure the PV module according to the user manual to ensure the open-circuit voltage is within the allowed range. Then, the alert will be automatically recovered.
2	Grid Power Outage	Grid power outage occurred.	<ul style="list-style-type: none"> Check whether the grid is normally powered. Check whether the alternating current cable or switch is disconnected.
3	Grid Undervoltage	The grid voltage is lower than the lower limit.	<ul style="list-style-type: none"> Check whether the grid voltage is within the allowed range. If not, contact your local electric system operator. If so, modify the grid undervoltage protection threshold after obtaining consent from your local electric system operator. If the fault persists, check whether the alternating current switch and cable are connected properly.
4	Grid Overvoltage	The grid voltage is higher than the upper limit.	<ul style="list-style-type: none"> Check whether the grid voltage is within the allowed range. If not, contact your local electric system operator. If so, modify the grid overvoltage protection threshold after obtaining consent from your local electric system operator. If the fault persists, check whether the alternating current breaker and cable are connected properly, or whether the cable complies with the recommended specifications.
5	Grid Underfrequency	The grid frequency is lower than the lower limit.	<ul style="list-style-type: none"> Check whether the grid frequency is within the allowed range. If not, contact your local electric system operator. If so, modify the grid underfrequency protection threshold after obtaining consent from your local electric system operator.

Code	Issue	Cause	Solution
6	Grid Overfrequency	The grid frequency is higher than the upper limit.	<ul style="list-style-type: none"> Check whether the grid frequency is within the allowed range. If not, contact your local electric system operator. If so, modify the grid overfrequency protection threshold after obtaining consent from your local electric system operator.
7	High Output Direct Current Component	The output direct current component is higher than the upper limit.	<ul style="list-style-type: none"> The device automatically manages external working conditions in real time and returns to normal after the fault is resolved. If the fault occurs frequently, contact your distributor or customer service.
8	Low Direct Current-Side Insulation Resistance	The insulation between the PV module and the ground is poor.	<ul style="list-style-type: none"> Check the insulation between the PV module and the ground. If there is a short circuit or poor insulation, rectify it.
9	Internal Device Error	The internal circuit of the microinverter failed.	<ul style="list-style-type: none"> Wait for the inverter to power on again until the next day. If the fault persists, contact your distributor or customer service.
10	Active Device Protection	The operating environment of the inverter is abnormal.	<ul style="list-style-type: none"> The device automatically manages external working conditions and returns to normal after the fault is resolved. If the alert is reported frequently, contact your distributor or customer service.

Maintenance

6.1 Remove the Microinverter

If, after the above troubleshooting, the microinverter still does not operate normally, please contact Atmoce technical support. After the warranty conditions are confirmed, the device can be removed and replaced.

The procedure is as follows:

- Disconnect the AC circuit breaker.
- Cover the PV modules with an opaque cover.
- Use a clamp meter to check and ensure that there is no residual current in the DC cable between the PV module and the microinverter, and then the PV module can be safely removed.
- Disconnect the DC connector between the microinverter and the PV module using the disconnect tool as shown in the figure.

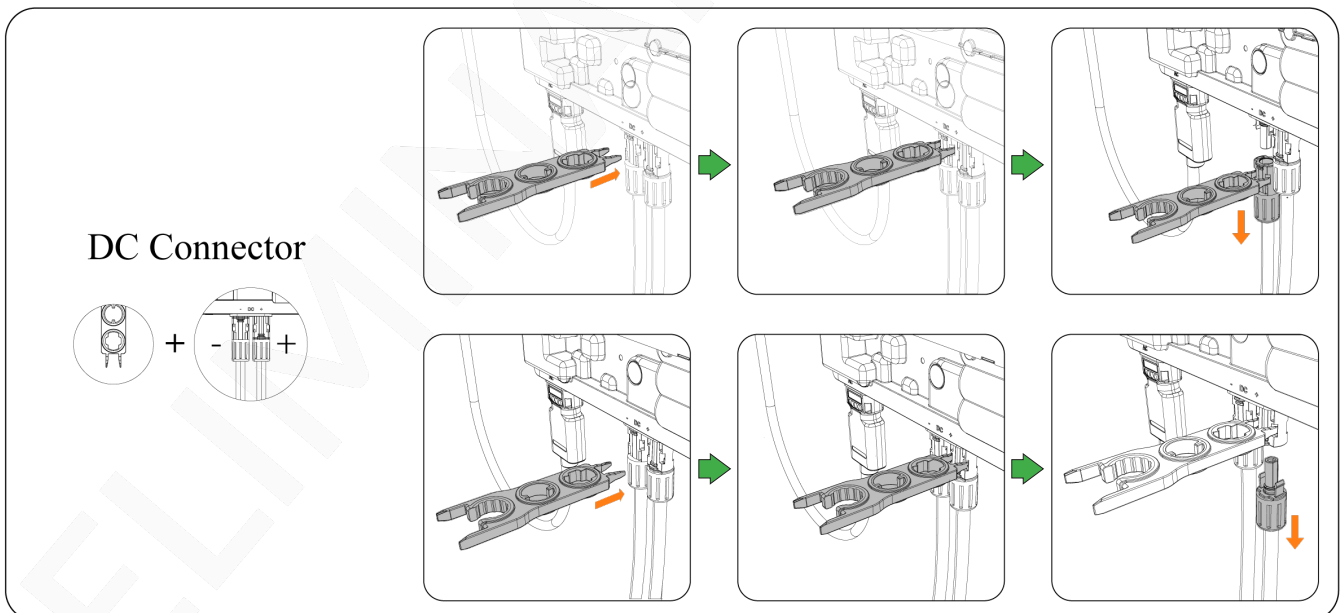

- e. Disconnect the AC connector of the microinverter using the disconnect tool as shown in the figure.
- f. Unscrew the screws on the top of the microinverter and remove the device from the PV rack.

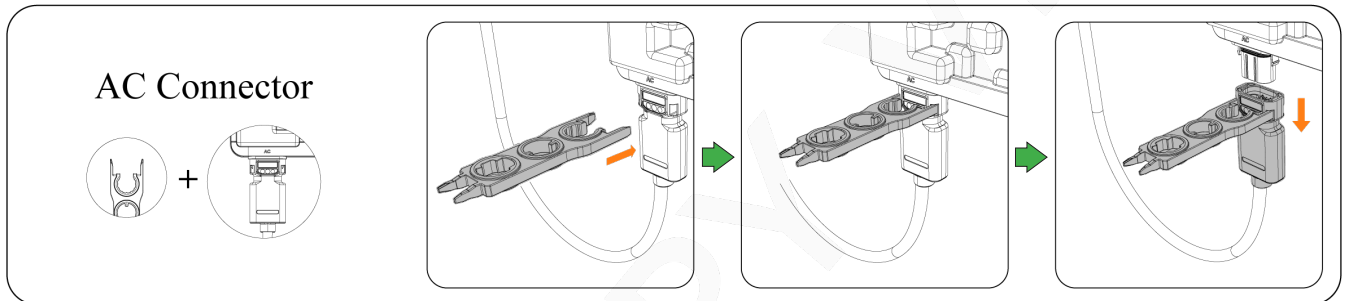
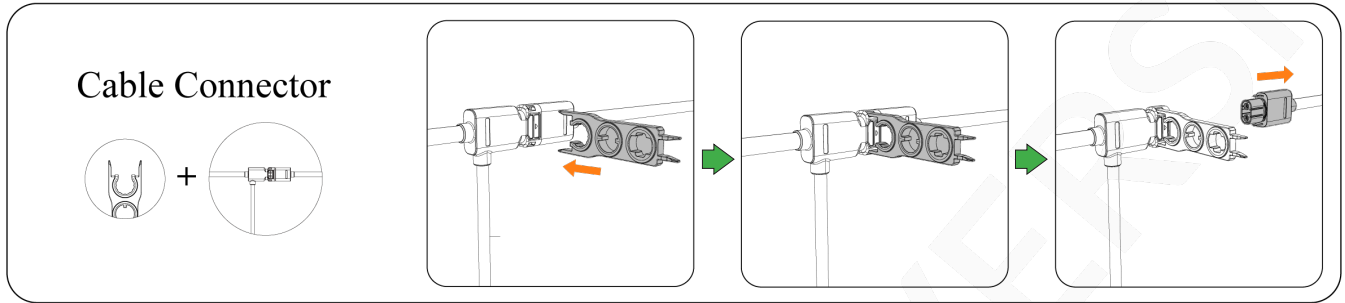

6.2 Replace the Microinverter

If, after the above troubleshooting, the microinverter still does not operate normally, contact Atmoce technical support. After the warranty conditions are confirmed, the device can be removed and replaced.

The procedure is as follows:

- a. Disconnect the AC circuit breaker.
- b. Remove the microinverter. For detailed instructions, refer to Section 6.1 Remove the Microinverter.
- c. Note down the SN of the removed microinverter.
- d. Reinstall the microinverter. For detailed instructions, refer to Chapter 4. Installation.
- e. Turn on the AC circuit breaker.
- f. Obtain the SN of the removed microinverter from the device list on Atmozen and replace the device. Below is the procedure:
 - Log in to Atmozen and select the site.
 - Click **Devices**.
 - Select the replaced device to view the details.
 - Click **Device replacement**.
 - Click the SN of the new microinverter.
 - Click **Confirm**.
- g. Check the operating status and information of the microinverter on Atmozen to confirm that it is operating normally.

Technical Data

7.1 MI Series Microinverters Data Sheet

Model		MI-500	MI-450	MI-425	MI-400
Input parameters					
PV module compatibility	/	54-cell/108 half-cell, 60-cell/120 half-cell, 66-cell/132 half-cell and 72-cell/144 half-cell			
Max. power of compatible PV modules	P_{dcmax} , W			700	
Max/Min. input voltage	U_{dcmin}/U_{dcmax} , V			16/60	
Peak power tracking voltage range	U_{mppmin}/U_{mppmax} , V	33 to 55		30 to 55	28 to 55
MPPT voltage range	V			16 to 60	
Nominal input voltage	U_{dcnom} , V			36	
Start-up input voltage	$U_{dcstart}$, V			22	
Max. continuous input current	I_{dcmax} , A			16	
Max. input short-circuit current	I_{scmax} , A			20	
DC port overvoltage class	/			II	
DC port backfeed current	A			0	
PV array configuration	/			1 x 1 ungrounded array	
Output parameters					
Nominal voltage	U_{acnom} , V			230	
Voltage range	U_{acmin}/U_{acmax} , V			184 to 276	
Nominal output power	P_{acnom} , VA	500	450	425	400
Nominal output current	I_{acnom} , A	2.17	1.96	1.85	1.74
Max. output current	I_{acmax} , A	2.28	2.06	1.94	1.83
Max. microinverters/25A branch circuit		9	10	10	11
Nominal frequency	f_{nom} , Hz			50/60	
Extended frequency range	f_{min}/f_{max} , Hz			45 to 65	
Power consumption at night	mW			0 ^a	
AC port overvoltage class				III	
Power factor setting	cosphi			>0.99	
Power factor (adjustable)				0.8 leading ... 0.8 lagging	
Total harmonic distortion	THD			<3%	
Efficiency parameters					
Peak efficiency	η_{max} , %			97.3	
EU efficiency	η_{EU} , %			96.7	
MPPT efficiency	η_{MPPT} , %			99.9	

Model		MI-500	MI-450	MI-425	MI-400
Mechanical parameters					
Ambient temperature range	°C		-40 to 65		
Storage temperature range	°C		-40 to 85		
Relative humidity range	%		4 to 100, condensing		
DC connector type			MT-02502-D ^b		
Number of DC connector			1 pair		
AC connector type			MT-02502-A ^c		
Number of AC connector			1 pair		
Dimensions (without bracket)	mm		248 × 164 × 36.5 (W x H x D)		
Weight (without bracket)	kg		1.3		
Cooling			Natural convection		
Approved for wet locations			Yes		
Pollution degree			III		
Topology			Isolated		
Enclosure protection class			Class II double-insulated		
Environmental category			Outdoor - IP67		
Altitude	m		3000		
Noise	dB		<25		
Features					
Communication			PLC		
Indicator			1 × LED		
Compliance					
Safety			EN IEC 62109-1/-2		
EMC			EN IEC 61000-6-1/-2/-3/-4, EN 62920		
Grid compliance			VDE 0124, VDE 4105, UTE 0126, EN 50549, EN 50530		

a. The value is tested with M-Relay or M-Combiner.
 b. The DC connector is compatible with MC4.
 c. The AC connector must be used with MW-Cables.

Appendix 1: Installation Map

INSTALLATION MAP

ATMOCE

Mark North with	Customer:	Installer:	Microinverter:	Panel: Azimuth: Tilt: Sheet ____ of ____	 V1.2.0				
	2	3	4	5	6	7	8	9	10
A	B	C	D	E					

To Sheet ____ ↑
To Sheet ____ ↓

Peel off the QR code label from the microinverter and paste it on the installation map. Then, create the site array in the Atmozen App accordingly.

Appendix 2: Wiring Diagram in Single-phase System

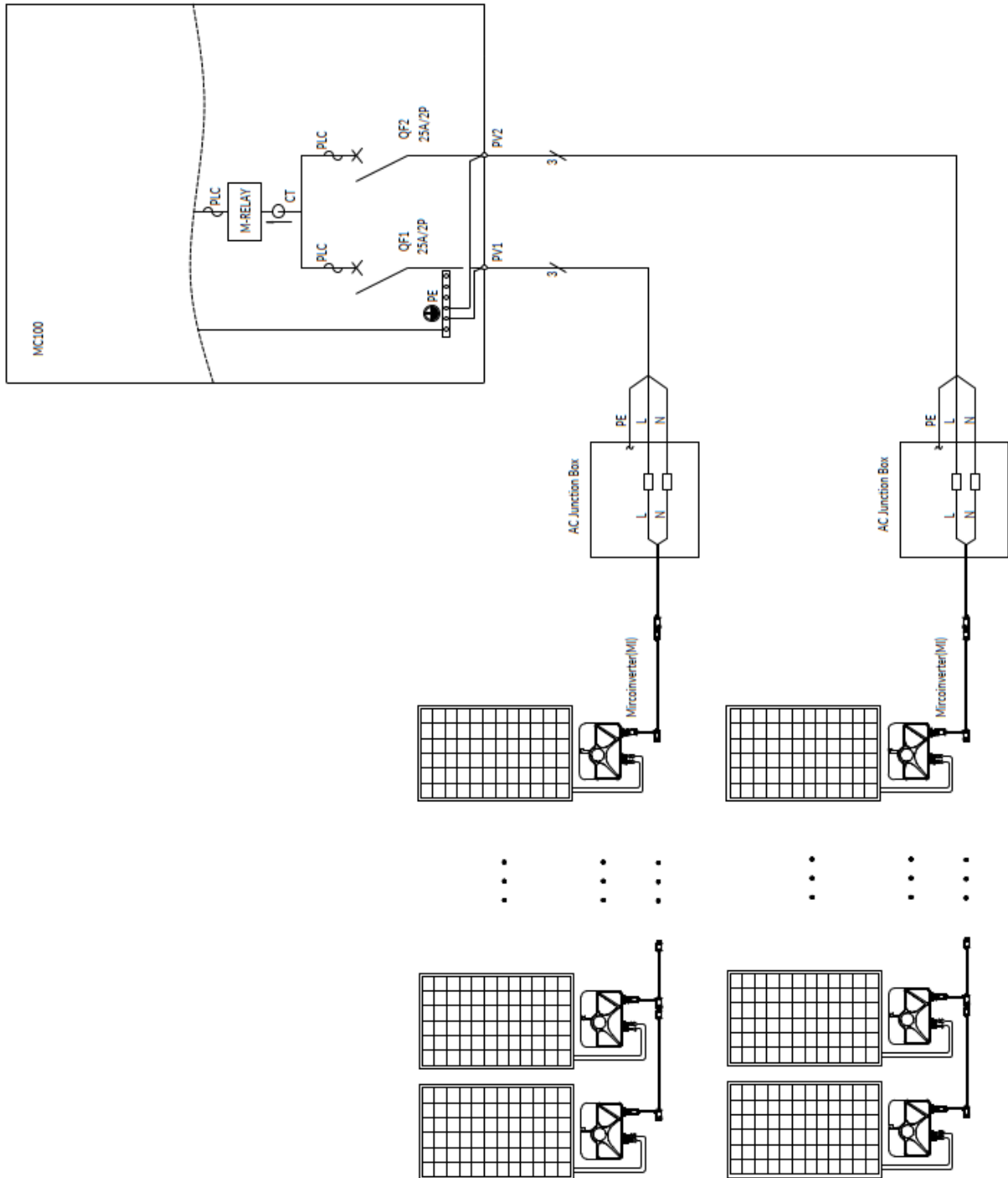

Appendix 3: Wiring Diagram in Three-phase System

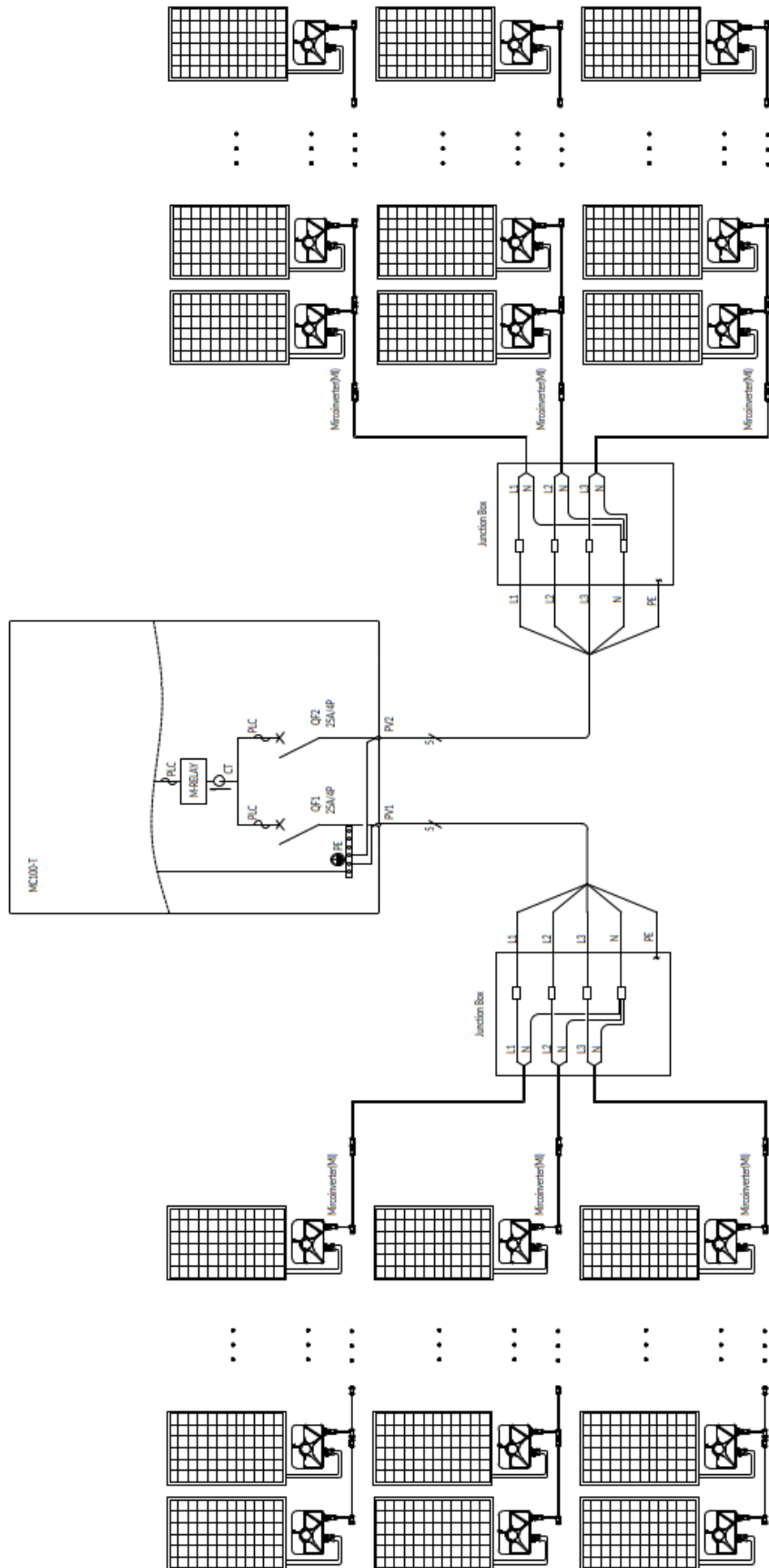

Appendix 4: Terms and Abbreviations

AC	Alternating current
APP	Application
CAT 6	Category 6
DC	Direct current
DI	Digital input
DO	Digital output
EMC	Electro Magnetic Compatibility
ETH	Ethernet
MPPT	Maximum power point tracking
PE	Protective earthing
PV	Photovoltaic
RH	Relative humidity
SN	Serial number
WEEE	Waste electrical and electronic equipment

Contact Details

Company: Atmoce Holding B.V.
Address: Singel 250, 1016AB Amsterdam, Netherlands.
Email: info@atmoce.com
Telephone: +31 6 39877352